

VORTEX: TECHNICAL SPECIFICATIONS

With the Mindstorm Vortex, you can make a lasting impression on your customers. Revolutionise your brand. Transform your services. Outshine your competitors.

With a captivating interactive surface that enables real-time collaboration with your customers, the Vortex is practical, playful and personal. Built at waist height for comfortable use, the Vortex can be an information guide in a hotel. A shopping catalogue in a fashion store. A delegate survey on an exhibition stand.

Using the multi-touch surface of the Vortex, customers can access dynamic information and manipulate virtual objects. Place product orders. Search maps and directories. Select music from playlists. All these activities can be carried out without the involvement of a receptionist or sales assistant.



VORTEX: TECHNICAL SPECIFICATIONS

TOUGHENED GLASS 

AWARD WINNING 

FULL CUSTOMER SUPPORT 

MINDSTORM: VORTEX

ALL MEASUREMENTS ARE IN MM

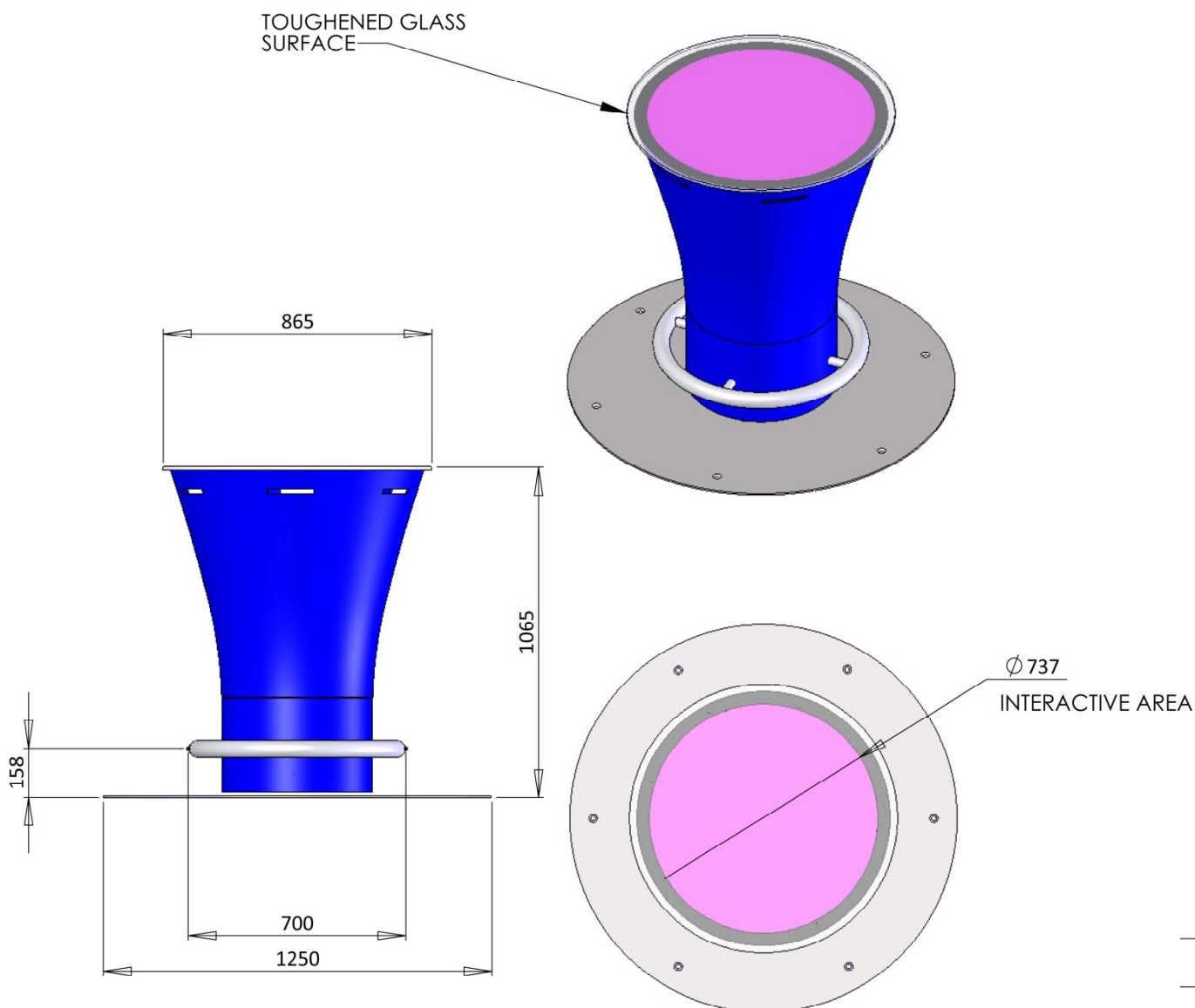

BRINGING A NEW DIMENSION TO CUSTOMER INTERACTIONS

For more information contact: www.mindstorm.com



MINDSTORM: 5 Parma House, Clarendon Road, London N22 6UL, UK
T: +44 20 8826 4600 | F: +44 20 8888 2520 | www.mindstorm.com

VORTEX: TECHNICAL SPECIFICATIONS

TOUGHENED GLASS 

AWARD WINNING 

FULL CUSTOMER SUPPORT 

MINDSTORM: VORTEX

BRINGING A NEW DIMENSION TO CUSTOMER INTERACTIONS

For more information contact: www.mindstorm.com

SIZE AND WEIGHTS

Dimensions (Height x Diameter) cm 110 x 82.5 (Approx)
Weight < 200 kg

INTERACTIVE AREA

Dimensions (Dia.) cm 74
Resolution of projection 1280 x 800 pixels
Aspect ratio 16:10
Projection frequency 60Hz
Projection Brightness 2100 lm
Contrast 2500:1
Colour Depth 32Bit

POWER

Power consumption 110-240V / 7 A

ENVIRONMENTAL

Ambient temperature (Operating) 5° to 30° C
Humidity Up to 80% RH

SOFTWARE (PRE-INSTALLED)

Operating system Windows XP Professional (service pack 2)
Mindstorm operating software
Tracking Mindstorm tracking software
Effects / Applications As per customer requirements

MULTI-TOUCH TRACKING PERFORMANCE

Maximum concurrent objects > 50 moving objects
Tracking frequency (fps) 60
Latency (ms) 6
IR illumination LED

CONNECTIVITY / COMMUNICATION

Gigabit LAN Standard
Wi-Fi (IEEE 802.11b/g/n) Optional
Bluetooth Optional
Audio Internal Stereo Speakers (optional)

SURFACE

Laminated & Toughened Glass 11.5 mm
Tensile strength >200 kg (distributed load)
Safety Standard BS EN 12150

OPERATING ENVIRONMENT

Power Consumption 1.7 kW
Mains Supply 100-240 VAC / 50-60Hz
Recommended max altitude 2000 m (6600 feet) above sea level
Temperature / Humidity 5 - 30°C 30 - 90 % RH
(non condensing)

MAINTENANCE / WARRANTY

MTBF 2000 Hrs @ 70 Hrs/Wk (projector bulb)
Recommended Service Interval Optics Service every 500 Hrs
Warranty 12 months (RTB)

CERTIFICATION

CE certified Date TBC in 2009

ACCESSORIES

1 x wireless keyboard with trackpad
1 x remote control for projectors

PACKAGING

Transportation pallet
Transportation cover

ADDITIONAL OPTIONS

Colour (RAL)
Over-Branding
Extended support

KEY FEATURES:



Integrated all-in-one package



Hardwearing toughened glass surface



Mindstorm tracking software provides high tracking resolution and reliable motion prediction



MINDSTORM: 5 Parma House, Clarendon Road, London N22 6UL, UK
T: +44 20 8826 4600 | F: +44 20 8888 2520 | www.mindstorm.com

